

0505V

20 BAR COMPRESSOR

OPERATING INSTRUCTIONS

12/2006

SERVICE MANUAL



Table of Contents

Chapter - Page

1	Technical Specification	1 - 4
1.1	Compressor Unit	1 - 1
1.2	Sound emission	1 - 1
1.3	Compressor Block	1 - 1
1.4	Electrical Connection	1 - 1
1.5	Drive Motor	1 - 2
1.6	Air Pressure Switch Setting	1 - 2
1.7	Safety Relief Valve Setting	1 - 2
1.8	Installation Requirements	1 - 2
1.9	Recommended Oil	1 - 3
1.10	Air Receiver Charging Time	1 - 3
1.11	Dimensional Drawing	1 - 4
2	Safety Regulations	2 - 8
2.1	Explanation of Symbols and References	2 - 5
2.2	General Safety Precautions	2 - 6
2.3	Additional Safety Precautions	2 - 7
2.4	Electrical Power Supply	2 - 7
2.5	Spare Parts	2 - 7
2.6	Environmental Protection	2 - 8
3	General	3 - 9
3.1	Proper Use of the Compressor	3 - 9
3.2	Improper Use	3 - 9
3.3	Copyright	3 - 9
3.4	Handling the Document	3 - 9
4	Transport	4 - 10
4.1	Transport Instructions	4 - 10
4.2	Storage	4 - 10
5	Construction and Operation	5 - 11
5.1	Principle of Compression	5 - 11
5.2	Brief Description	5 - 11
5.3	Compressor Control (Stop—Start Control)	5 - 11
5.4	Components of the Compressor Unit	5 - 12
6	Installation	6 - 13
6.1	Installation Instructions	6 - 13
6.2	Connection of the Compressed Air Supply	6 - 13
6.3	Electrical Connection	6 - 13
		Chapter - Page
7	Putting into Operation	7 - 14
7.1	Points to be Observed before Putting into Operation	7 - 14
7.2	Function of the Overload Protection Switch	7 - 15
7.3	Setting the Air Pressure Switch	7 - 15
7.3.1	Cut—in frequency of the compressor unit from “standstill” to “load”	7 - 16
7.4	Setting up the Pressure Reducer	7 - 17



Table of Contents

8 Operation	8 - 18
8.1 Starting and Stopping the Compressor Unit	8 - 18
8.1 Trouble Shooting: Possible cause - Remedy.....	8 - 18
8.2.1 Compressor does not start	8 - 18
8.2.2 Compressor starts with difficulty	8 - 19
8.2.3 Compressor overheating.....	8 - 19
8.2.4 Motor overload protection switch releases after a short period	8 - 19
8.2.5 Motor overload protection switch releases after a long period.....	8 - 19
8.2.6 Compressor runs continuously, discharge pressure not reached	8 - 20
8.2.7 Compressor cutting in too often.....	8 - 20
8.2.8 Compressor shuts down, air escapes constantly at the unloading valve	8 - 20
8.2.9 Air escapes from the unloading valve when the compressor is running	8 - 20
8.2.10 Unloading valve not unloading after shut—down	8 - 20
8.2.11 Air escapes from the pressure switch	8 - 20
8.2.12 Whistling noises at the cylinder head.....	8 - 21
8.2.13 Safety valve blowing off prematurely	8 - 21
8.2.14 Oil consumption of compressor too high	8 - 21
9 Maintenance	9 - 22
9.1 Observe the following rules during all maintenance and servicing work:	9 - 22
9.2 Regular Maintenance Work.....	9 - 23
9.3 Oil Level Check and Top-Off (Compressor Block)	9 - 24
9.4 Air Receiver.....	9 - 25
9.5 Oil Change (Compressor Block).....	9 - 25
9.6 Cleaning or Changing the Air Filter.....	9 - 26
9.7 Cleaning or Replacing the Check Valve.....	9 - 27
9.8 Testing the Safety Relief Valve.....	9 - 27
9.9 Maintenance of the Motor Bearings.....	9 - 28
9.10 Clean the unloading valve on the pressure switch.....	9 - 28
9.11 Inspect the cylinder head and valves and renew if required	9 - 29
9.12 Checking Compressor Unit Performance	9 - 29
9.13 Maintenance Schedule.....	9 - 30
10 Spare Parts and After Sales Service	10 - 31
10.1 Service Parts and Maintenance Parts.....	10 - 31
10.2 Ordering Spare Parts	10 - 31
11 Appendix	11 - 32
11.1 Electrical Diagram	11 - 32



1 Technical Specification

1.1 Compressor Unit

ModelPremium compact 130/4 W
Maximum gauge working pressure..... 290 psig W
eight..... 71 lbs Air
receiver:
Capacity..... 1 gal Max.
permissible gauge working pressure.....290 psig Draw-
ings:
Dimensional drawing..... 0505V#### - Mech.
Electrical diagram0505V#### - Elec.

1.2 Sound emission

Guaranteed sound power level 99 dB(A) (to
2000/14/EG Directive)
Emission sound pressure level77.5 dB(A)
calculated from the measured mean sound power level (Directive 2000/14/EG, basic standard for noise
measurement ISO 3744) to EN ISO 11203:1995 para. 6.2.3.d at distance d= 1m, Q.2= 12.9 dB (A).

1.3 Compressor Block

Model0505V#### -3000
Theoretical inlet capacity4.6 cfm
Free air delivered at 87 psi gauge working pressure2.8 cfm
Maximum gauge working pressure..... 290 psi
Number of cylinders 1
Speed 3600 rpm
Oil capacity 0.13 qts
Oil top-up quantity..... 0.05 qts

1.4 Electrical Connection

Main voltage.....230V - 1PH
Full load current FLA5.6 A
Frequency60 Hz
Recommended main disconnect fuses
(Dual element or time-delay)6 A
Recommended power supply cable (Cu multi—stranded) cross—section.....14 AWG

CAUTION | Maximum dual element time-delay fuses are selected according to
2002 N.E.C. Article 240-6, 430-52 and Tables 430-52, 430-148 & 150.
Select multi-strand copper core wire at 40° C ambient temperature
according to 2002 N.E.C. 110-14(c), 220-3, 310-15, Table 310-16,
430-6, 430-22, 430-24 and Tables 430-148 & 150.



Technical Specification

Under unsuitable mains conditions, operation of the compressor can have an adverse effect on other equipment. No interference should be expected if the mains network impedance is less than 0.3Ω (ohms). Generally, the maximum permissible impedance will not be exceeded if the compressor is supplied from a domestic power outlet or a sub—distribution cabinet with a rated current of 25 A.

1.5 Drive Motor

Rated power.....1.0 hp
Rated speed 1800 rpm
Enclosure ratingTEFC
Phasessingle—phase
Max. starts per hour 30 times

1.6 Air Pressure Switch Setting

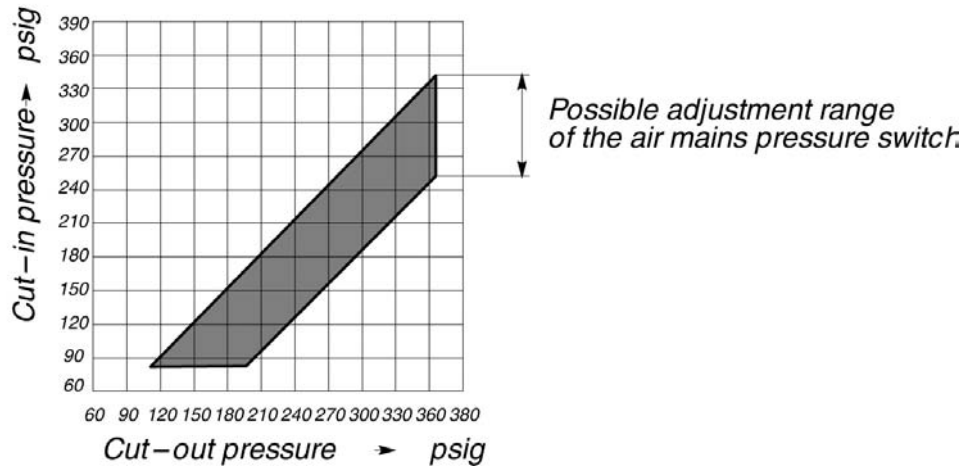

Factory settings:

Cut-in pressure p_{\min} 225 psig Cut—
out pressure p_{\max} 290 psig Settings specific to a
customer may differ.

1.7 Safety Relief Valve Setting

Set point.....290 psig

1.8 Installation Requirements

Max. height above sea level at place of installation 3000 ft.
(for all heights above please contact authorized Soilmoisture Equip. Corp. distributor)
Min. ambient temperature 40 ° F
Max. ambient temperature 95 ° F

1.9 Recommended Oil

THIS COMPRESSOR COMES UNFILLED WITH OIL ..IT MUST BE FILLED PRIOR TO USE

Oil type	SAE 5 W30	FGP
Description	High performance oil for workshop compressors	Synthetic oil
Application:	Suitable for all applications except in connection with foodstuff processing.	Specially for use in compressors where the air comes in direct contact with foodstuff.
Maximal permissible fluid change interval in operating hours/years	1000/2*	1000/2*
Material (part) number/ quantity	9.4943.00010/ 0.5	9.0874.0/ 1.0
Type of oil filled**		

* Cool to moderate ambient temperatures, low humidity, high duty cycle

** Mark the type of oil in your machine in the table

1.10 Air Receiver Charging Time

Air receiver charging time to 145 - 290 psig 0 min 46 s

1.11 Mechanical Drawing with Some Dimensions

(see following page)

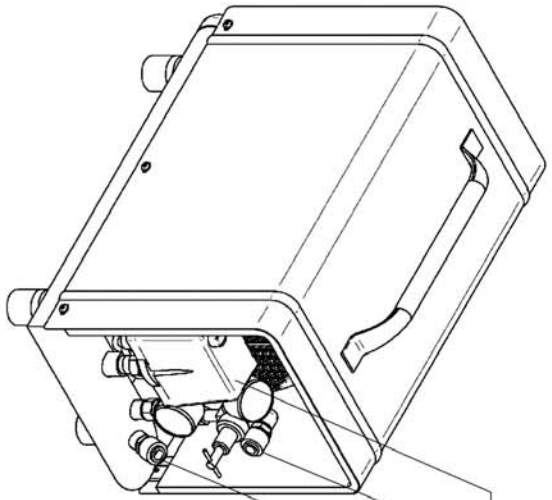

Pressure Switch - Off - On

- Quick Connect - Regulated air
- STD BSPT - 3/8" Connect
- Quick Connect - Unregulated air
- STD BSPT - 3/8" Connect

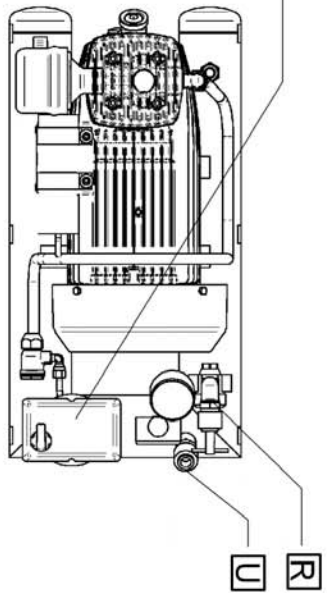

OIL FILLING PORT
pull out and fill

Oil Sight Port
(do not overfill)

Air Receiver Drain Valve

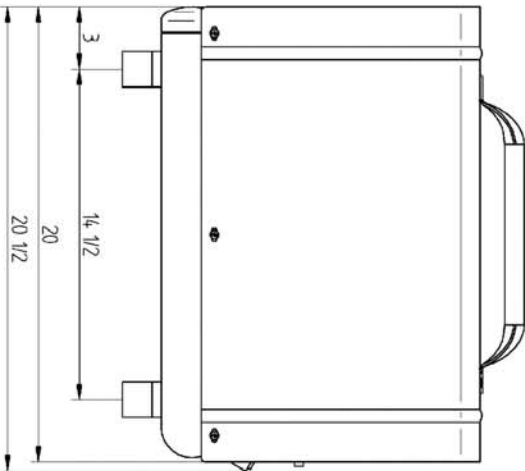
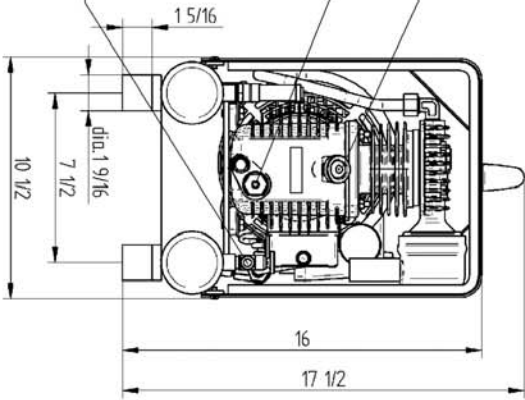

	Solmoisture Equipment Corp
	Model 0505V - 20 Bar Compressor
MECHANICAL DESIGN SPECS	

2. Safety Regulations

Disregarding this notice can result in serious injury!

Read this service manual carefully and observe cautionary references before putting the compressor unit into operation and before carrying out any maintenance on the unit.

The machine is constructed to the latest technological standards and to accepted safety regulations.

Despite this fact, physical danger to the user or third parties or damage to the machine and other property exists.

Use the machine as specified according to the service manual and only if it is in perfect technical order!

Repair defects that could degrade safety (or have them repaired) immediately!

2.1 Explanation of Symbols and References



This symbol is placed before all regulations concerning safety where dangerous life and limb can occur during work. It is especially important that these regulations are observed and that extreme care is taken. For their own protection, inform all other users of these safety regulations. Observe all general safety and accident prevention regulations as well as the those laid down in this service menu

Caution

This symbol is placed by text where considerable attention must be paid to recommendations, regulations, references and the correct sequence of work so that damage and/or destruction of the compressor unit and/or other equipment is prevented.



This symbol identifies environmental care measures.



This symbol indicates operations and actions to be carried out by the operator or service technician.



This bullet identifies listings.



This warning label identifies hot surfaces:
DO NOT TOUCH!



DO NOT DO THIS

2.2 General Safety Precautions



Work on power-driven equipment may only be carried out or supervised by persons trained in that particular equipment or by a specialist.

Work on the electrical equipment of the compressor unit may only be carried out by a qualified electrician or trained personnel under the supervision of a qualified electrician according to the NEC and any applicable local codes.



Prior to working on electrical systems of the compressor always perform the following steps in the sequence shown.

1. Lock the main disconnect in the “off” position in accordance with applicable lock out/ tag out procedures (example: OSHA CFR 29 § 1910.147) to ensure the compressor does not restart.
2. Ensure the package cannot be switched on again
3. Check that no voltage is present
4. Lock the isolation shut-off valve in the “closed” position and vent all compressed air trapped between the compressor and the isolation shut-off valve in accordance with applicable lock out/ tag out procedures (example: OSHA CFR 29 § 1910.147).



The following actions must be carried out in the order given before working on any pressurized parts or enclosures (e.g. pipes, vessels, valves).

1. Shut off and depressurize all pressurized components and enclosures
2. Secure them in the depressurized state
3. Check that they are indeed de-pressurized

Caution

Any alterations or reconstruction carried out without the prior written authorization of Soilmoisture Equipment Corp. will invalidate the warranty.

Caution

No welding, heat-treatment or mechanical work may be carried out on pressure retaining components, e.g. pipes, air mains, receivers, etc.

Caution

Safety devices may not be modified or deactivated.

Signs and labels of reference may not be removed or rendered unreadable.

2.3 Additional Safety Precautions

Caution Comply with the following:

- Do not allow open flame and flying sparks at the installation site.
- Take necessary precaution when welding on or near the compressor unit to ensure that sparks or high temperatures cannot cause fire or explosion.
- Ensure that the compressor unit is supplied only with clean uncontaminated air.
- Do not allow the maximum ambient temperature to be exceeded (see chapter 1.8), unless special measures have been agreed upon between the manufacturer and the customer.
- This machine is not explosion-proof.
It may not be operated in areas in which specific requirements with regard to explosion protection are applied.

2.4 Electrical Power Supply

Caution The main power supply and over current protection must be installed by a qualified electrician in accordance with NEC, OSHA and any applicable local codes.

Compressor units must be installed with a lockable main disconnect and fuses or other short-circuit and ground fault protection device.

For fuse and wire recommendations, see chapter 1.4

Please note that the conductors, fuses and procedure are Soilmoisture's recommendations. These recommendations do not supersede other applicable codes.

2.5 Spare Parts

Safe and reliable operation of the compressor unit is guaranteed only with original spare parts.

2.6 Environmental Protection

Condensate drainage



Condensate accumulating during compression must be drained via a suitable draining system and collected in disposal canisters. The condensate must be disposed of according to environmental care regulations.

Maintenance materials/wear items/replacement parts



Dispose of all used materials and parts accumulating during operation, maintenance and repair of the compressor unit according to environmental care regulations!

Disposing of the Machine



Dispose of all used materials and parts accumulating during operation, maintenance and repair of the compressor unit according to environmental care regulations!

When disposing of a machine, drain out all liquids and remove dirty filters.



Take the machine out of service (see chapter 8.1).



Drain all oil completely from the machine (see chapter 9.5).



Remove dirty filters.

Use the services of an approved local disposal specialist to ensure environmentally correct disposal of the empty machine.

3 GENERAL

** The service manual must always be available at the compressor unit's place of use **

3.1 Proper Use of the Compressor





The compressor unit is intended solely for the purpose of generating compressed air. Any other use is considered improper. The manufacturer cannot accept liability for any damage caused by such improper use; the user alone is liable for any risks incurred.

Proper use of the compressor also includes compliance with the installation, removal, application, operational and maintenance instructions laid down by the manufacturer.

Caution

The equipment may only be used or serviced by authorized and trained personnel.

3.2 Improper Use



-  Never direct compressed air toward persons. Compressed air is a concentrated form of energy and as such dangerous to life.
-  Never use compressed air for breathing purposes and production methods where the air has direct contact with food without subjecting the compressed air to additional treatment.
-  Inlet air may not contain any explosive or chemically unstable gas or vapor.
-  Danger of injury and/or damage: Under no circumstances are persons allowed to climb on this compressor.
-  Do not place any objects on the compressor or use it as a working surface.

3.3 Copyright

This Manual produced by Soilmoisture Equipment Corp., USA. in cooperation with Keaser Compressors, Inc of Germany . All rights reserved. No part of this manual may be reproduced in any form without permission of these parties.

3.4 Handling the Document

The service manual is part of the machine.

-  Keep the service manual safe throughout the life of the machine.
-  Pass the manual on to the next owner/user of the machine.
-  Ensure that all amendments are entered in the manual.

4 Transport

4.1 Transport Instructions

Always use a fork lift truck, a lift truck or lifting equipment when transporting the compressor unit to avoid damage to cabinet and framework.

See chapter 1.1 for details of the weight.

4.2 Storage

Always store the compressor, whether packaged or not, in an enclosed dry location. The ambient temperature may not exceed the limits of: — 13 ° F and + 140 ° F

5 Construction and Operation

5.1 Principle of Compression

The compressor is an air cooled, oil lubricated reciprocating compressor working on the single stage principle of compression.

Atmospheric air is drawn in through the air filter into the compression chamber of the compressor block. The downward movement of the piston creates a vacuum. When the piston has passed the bottom dead center the air drawn into the cylinder is compressed by the upward movement of the piston. At the same time the inlet valves close and the outlet valves open.

The compressed air is forced through a check valve into the air receiver. The check valve prevents the compressed air flowing back from the air receiver to the compressor block after shut-down.

5.2 Brief Description

The compressor block is driven by an electric motor. The compressor block is directly coupled to the motor via the motor shaft. A fan supplying the cooling air necessary for the motor and compressor block is fitted to the other end of the shaft.

The heat generated is dissipated via the cooling fins on the cylinder and the cylinder head.

The crankshaft is supported by anti-friction bearings; the connecting rod is supported by shell bearings. The cylinder liner, piston, crankshaft and connecting rod are splash lubricated.

To enable an unloaded start the pressure switch is fitted with an unloading valve.

A check valve is fitted upstream of the air receiver to prevent compressed air flowing back into the block.

The air receiver is constructed to the regulations of the pressure vessels act and fitted with all necessary fittings such as safety valve, pressure gauge, pressure switch and check valve.

5.3 Compressor Control (Stop-Start Control)

The compressor is controlled by the pressure switch.

After the compressor is first switched on the pressure switch switches the compressor, depending on the air demand, between the two operating states "load" and "standstill" within the limits P_{min}/P_{max} .

See chapter 1.6 for the works setting of the pressure switch.

The compressed air pipe from the compressor block up to the check valve is vented when the cut-out gauge pressure is reached to ensure an unloaded compressor start.

Caution

When operating in this mode, the compressor must be allowed to shut off every 30 minutes for at least 5 minutes.

5.4

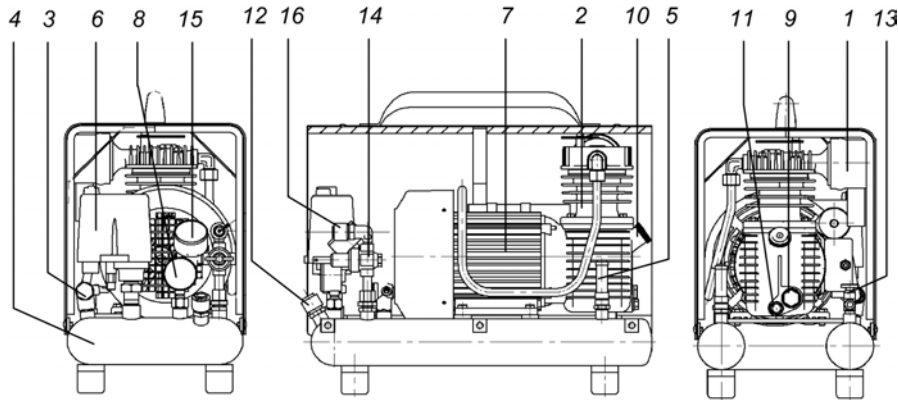

Components of the Compressor Unit

- 1 Air filter; cleans the inlet air
- 2 Compressor block; draws in the air and compresses it to the discharge pressure
- 3 Check valve; prevents the compressed air from flowing back into the block
- 4 Air receiver; compressed air tank and accumulation of condensate
- 5 Safety valve on the air receiver; protects the air receiver, blows off if the max. pressure is exceeded
- 6 Pressure switch; controls compressor stop and start
- 7 Electric motor; drives the compressor block, Fan on OD shaft end provides the necessary cooling air
- 8 Pressure gauge; indicates the current pressure in the air receiver
- 9 Oil level sight glass
- 10 Oil filler
- 11 Oil drain plug
- 12 Compressed air discharge connection on the air receiver
- 13 Condensate drain cock
- 14 Pressure reduction valve; reduces the pressure to the required working pressure
- 15 Pressure gauge on reduction valve; indicates the working pressure
- 16 Compressed air discharge connection on the reduction valve

6 Installation

6.1 Installation Instructions

To ensure sufficient ventilation, the compressor unit must be installed with a minimum distance of 19.7 inches to the wall.

Safe operation of the compressor unit is only ensured if the ambient temperature remains within the limits stated in chapter 1.8).

If the compressor is used in the open, take care that it is protected against the direct rays of the sun and against the ingress of dust and rain.

6.2

Connection of the Compressed Air Supply

The compressor unit is piped ready for use.

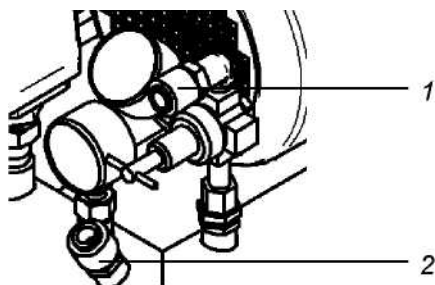

6.3

- 1 Compressed air discharge connection on the pressure reduction valve
- 2 Compressed air discharge connection on the air receiver

Two compressed air connections are provided for the consumers. The consumers are connected via a flexible hose and a coupling.

Electrical Connection



The main power supply and overcurrent protection must be installed by a qualified electrician in accordance with NEC, OSHA and any applicable local codes.

For fuse and cable recommendations, see chapter 1.4.

The compressor is wired ready for connection to the power supply with a mains plug.

Caution

Maximum dual element time-delay fuses are selected according to 2002 N.E.C. Article 240-6, 430-52 and Tables 430-52, 430-148 & 150.

Select multi-strand copper core wire at 40° C ambient temperature according to 2002 N.E.C. 110-14(c), 220-3, 310-15, Table 310-16, 430-6, 430-22, 430-24 and Tables 430-148 & 150.

1.25 x LA (see chapter 1.4)	wire temperature rating	correction factor for 40° C
<100A	60° C	0.82
>100A	75° C	0.88

7 Putting into Operation

7.1 Points to be Observed before Putting into Operation

Every compressor unit is given a test run at the factory and carefully checked before shipment. The test run confirms that the compressor unit conforms to the specification data and runs perfectly. However, independent of the checks made at the factory, the compressor unit could be damaged during transport. For this reason, we recommend that the compressor unit is examined for such possible damage. Observe the compressor unit carefully during the first hours of operation for any possible malfunction.

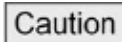

Important functional components in the compressor unit (such as check valve, safety relief valve and solenoid valve) are adjusted and fitted to factory standards and specifications. Alterations to these components are not allowed without prior written authorization from the manufacturer.

Do not disassemble the check valve and safety relief valve. They are heavily spring loaded.

Points to be observed before starting the compressor unit:



ANY NON-OBSERVANCE OF THIS OR OTHER REFERENCES (WARNING; ATTENTION; DANGER) CAN LEAD TO ACCIDENTS CAUSING INJURY TO PERSONS OR DAMAGE TO EQUIPMENT.

The compressor unit starts automatically after a power failure providing the line pressure is lower than the setting on the air pressure switch.



Do not operate the compressor without belt guards or open doors as injury to persons could occur from the drive belts and electrical equipment.



Remove all packaging materials, tools and transport securing devices on and in the compressor unit.

- It is expected that the user employs safe working techniques and that all lawful operating and safety regulations are followed when operating this compressor unit.
- The operator of this compressor unit is responsible for its safe operating condition.
- Do not operate this compressor unit in locations where heavy dust conditions, poisonous or inflammable gases could exist.
- Do not connect the compressor unit to a supply voltage other than that stated on the nameplate.
- Install the compressor unit in a location not subject to freezing temperatures. The air temperature requirements at the air intake must be complied with (see chapter 1.8).
- During installation of the compressor unit, ensure that a distance of at least 19.7 " is kept between the air intake of the unit and any wall.



Lock the main disconnect in the "off" position in accordance with applicable lock out/tag out procedures (example: OSHA CFR 29 § 1910.147) to ensure the compressor does not restart.

Check all screws on the electrical connections for tightness and tighten if necessary (carry out this check again after 50 hours of operation).

7.2 Function of the Overload Protection Switch

The alternating current motor is provided with a thermal overload protection switch that is preset to a fixed value.

Voltage fluctuations can release the overload protection switch because of increasing motor current, shutting down the compressor unit.

If the overload protection switch has released and shut down the compressor unit, start the compressor again as follows:

Caution

Before pressing the release button, turn the ON/OFF switch of the pressure switch to the “0” position first.

Turn the ON/OFF switch to the “0” position.

Press the release button

Turn the ON/OFF switch to the “1” position.

Caution

If the release button does not latch in straightaway, wait until the motor has cooled down.

Caution

If the overload protection switch repeatedly shuts down the compressor over a succession of short periods, other defects (e.g. insulation fault on the motor or in the cables, seized compressor) could cause the overload protection switch to release. Have the motor checked by a qualified electrician.

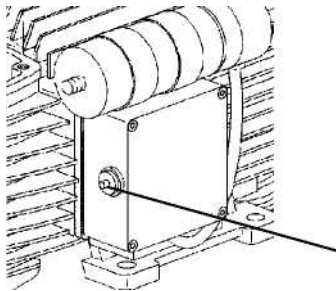

1 Overload protection switch (release button)

7.3 Setting the Air Pressure Switch



Lock the main disconnect in the “off” position in accordance with applicable lock out/tag out procedures (example: OSHA CFR 29 § 1910.147) to ensure the compressor does not restart. See chapter 2.4 for the main disconnect switch.

See chapter 1.6 for the factory setting of the air pressure switch and the possible setting range.

Caution

Do not adjust pressure switch unless it is mounted and pressurized.

Do not set the maximum cut-out pressure higher than the maximum gauge working pressure (see chapter 1. 1).

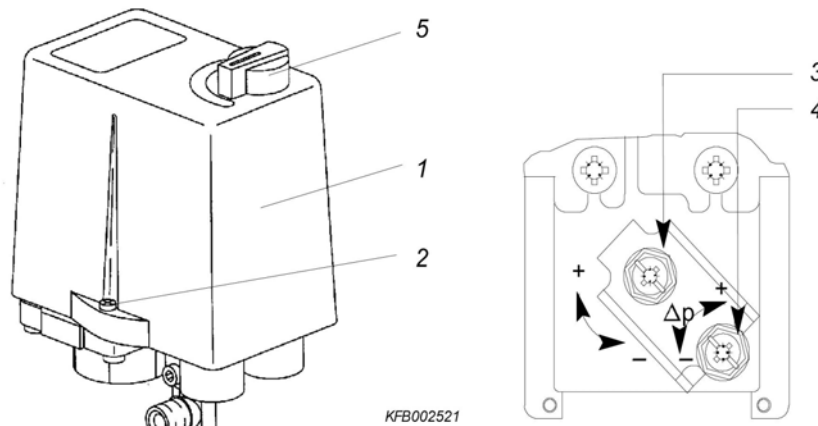

KFB002521

- 1 Cover
- 2 Screw
- 3 "Upper switching point" (Cut-out pressure) adjusting screw
- 4 Pressure difference adjusting screw
- 5 ON/OFF - Switch

 Shut down the compressor unit (see chapter 8.1).



Lock the main disconnect in the "off" position in accordance with applicable lock out/tag out procedures (example: OSHA CFR 29 § 1910.147) to ensure the compressor does not restart. See chapter 2.4 for the main disconnect switch.

 Unscrew the screws (2) to the right and left of the cover (1).

 Remove the cover (1) of the pressure switch.

 Carry out the adjustment of the pressure switch.



Replace the cover (1) after every adjustment of the pressure switch and before starting the compressor unit.

 Replace the cover (1).

To increase the cut-out pressure:

 Turn the screw (3) clockwise in the "+" direction.

To decrease the cut-out pressure:

 Turn the screw (3) counterclockwise in the "-" direction.

To increase the pressure difference between the cut-in and cut-out pressures:

 Turn the screw (4) clockwise in the "+" direction.

To decrease the pressure difference between the cut-in and cut-out pressures:

 Turn the screw (4) counterclockwise "-" direction.

7.3.1 Cut-in frequency of the compressor unit from "standstill" to "load"

The cut-in frequency of the compressor unit from "standstill" to "load" can be changed within a limited range by changing the switching difference. To change the cut-in frequency the pressure switch must be adjusted (see chapter 7.3).

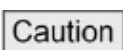

See chapter 1.5 for the maximum cut-in frequency from "standstill" to "load" per hour.

- Increasing the switching difference causes a decrease in the cut-in frequency.
- Decreasing the switching difference causes an increase in the cut-in frequency.

7.4 Setting up the Pressure Reducer



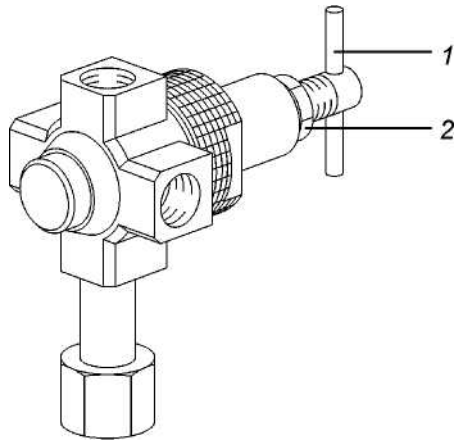

The working pressure of a compressor unit fluctuates according to the pressure limits set on the pressure switch (see chapter 1.6).

The pressure reducer reduces this fluctuating working pressure to the working pressure required and holds it constant.



1 Regulating screw

2 Locking nut

-  Switch on the compressor unit and allow it to run without any consumers until the cut-out pressure is reached.
-  Turn the regulating screw (1) anticlockwise until no more resistance is felt. This measure unloads the pressure reducer.
-  Turn the regulating screw (1) clockwise until the required pressure is indicated on the pressure gauge (3).
-  Lock the regulating screw (1) to this position with the locking nut (2).

8 Operation

8.1 Starting and Stopping the Compressor Unit

Starting the compressor unit

 Operate the main disconnect device (main switch or plug, see chapter 2.4).

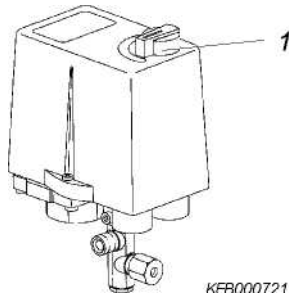

1 ON/OFF switch
 "0" position = OFF
 "1" position = AUTO

 Switch on the compressor unit at the pressure switch (turn switch to position "1").

Shutting down the compressor unit

 Switch off the compressor unit at the pressure switch (turn switch to position "0").

 Operate and lock out the main disconnect device (pull out the mains plug) to isolate the compressor from the mains power supply.

8.2 Trouble Shooting: Possible cause - Remedy



Always comply with all general and local safety regulations when carrying out faultfinding and repair.

Restarting after a fault:

see chapter 7. "Initial Start—up"

Explanation of symbols in the following faultfinding help:

- ▲ 1----have checked by a specialist.
- ▲ 2 — contact you authorized Soilmoisture distributor.

8.2.1 Compressor does not start

Possible cause:

- No motor power supply, fuses blown.
- Contact in pressure switch defective.
- Motor overload protection switch released.

Remedy:

- Replace the fuses; ▲ 1.
- Replace the pressure switch; ▲ 1.
- Check function of the overload protection switch (see chapter 7.2); ▲ 1.

8.2.2 Compressor starts with difficulty	
Possible Cause	Remedy
Unloading valve at the pressure switch not opening.	Clean or renew the unloading valve (see chapter 9.10); ▲ 1.
Damaged bearings.	Renew the bearings or fit an exchange compressor; ▲2
Pistons siezed (no oil or wrong oil).	▲2.
Power supply fault. Voltage too high or too low.	Check the power supply (fuses); ▲ 1.
Oil level too high.	Check the power supply (fuses); ▲ 1.

8.2.3 Compressor overheating	
Possible Cause	Remedy
Ambient temperature too high (over 105 F°).	Lower the ambient temperature (see chapter 1.8.)
The fan cannot draw in air freely.	Ensure that inlet air is available for the fan.
Valve plate leaking, corroded or the valve reeds are broken.	Replace valve plate; ▲ 1 and ▲2.

8.2.4 Motor overload protection switch releases after a short period	
Possible Cause	Remedy
Defect in the main power supply, voltage too high or too low.	Check the mains (fuses); ▲ 1.
Defect on the motor.	Change the motor;▲1 and ▲2.

8.2.5 Motor overload protection switch releases after a long period	
Possible Cause	Remedy
Defect in the main power supply, voltage too high or too low.	Check the cable cross-section; (see chapter 6.3); ▲1. Check the terminal connections; tighten screws if necessary.



8.2.6 Compressor runs continuously, discharge pressure not reached

Possible cause:

Air filter blocked.

Valve plate leaking, coked or valve reeds broken.

Pressure losses within the unit.

Air demand higher than the capacity of the compressor.

Losses at the consumer / in the air main.

Remedy:

Clean or replace the air filter (see chapter 9.6); □1.

Check, decoke or replace valve plate; >fc and □2.

Brush soapy water on piping and fittings, seal leaks, replace leaking parts; □1.

Extend the compressed air supply.

Check for possible leakage points.

8.2.7 Compressor cutting in too often

Possible cause:

Air receiver filled with condensate up to the discharge valve.

Remedy:

Drain the condensate (observe environmental care regulations), carry out routine maintenance regularly (see chapter 9.4); □ 1.

8.2.8 Compressor shuts down, air escapes constantly at the unloading valve

Possible cause:

Defective unloading valve.

Remedy:

Replace the seal or replace the valve cone (see chapter 9.7); □1.

8.2.9 Air escapes from the unloading valve when the compressor is running

Possible cause:

Unloading valve not closing (dirty or defective).

Remedy:

Clean or replace the unloading valve (see chapter 9.10); □1.

8.2.10 Unloading valve not unloading after shut-down

Possible cause:

Dirty unloading valve.

Remedy:

Clean the unloading valve (see chapter 9.10); □ 1.

8.2.11 Air escapes from the pressure switch

Possible cause:

Defective diaphragm. Unloading valve does not close.

Remedy:

Replace the pressure switch; □1.

Replace the unloading valve; □ 1.

8.2.12 Whistling noises at the cylinder head

Possible cause:

Loose cylinder head bolts or defective gas-kets.

Remedy:

Tighten the bolts or replace the gaskets; □ 1 and □ 2.

8.2.13 Safety valve blowing off prematurely

Possible cause:

Safety valve blows, even though the cut-out pressure is not yet reached.

Defective valve spring.

Wrong set point.

Safety valve was opened, dirt particles stuck in valve seat.

Remedy:

Check that the pressure gauge functions correctly, replace if necessary. Check the pressure setting.

Replace the safety valve; □ 1.

Set 10-15 psig above max. working pressure (see chapter 1.1) of the compressor unit; □ 1.

Open the safety valve completely for a short period to allow it to blow itself clean.

8.2.14 Oil consumption of compressor too high

Possible cause:

Viscosity of oil too low.

Defective crankcase venting system.

Piston rings worn or damaged.

Piston rings worn or damaged after only a short period.

Remedy:

Fill with correct oil (see chapter 1.9); □ 1.

Clean the crankcase venting system or replace the filter; □1.

Replace piston rings and cylinder; □2.

Replace piston rings and cylinder; □2. (ensure that the inlet air is clean, e.g. by using an air filter with a higher grade of filtration).

9 Maintenance

9.1 Observe the following rules during all maintenance and servicing work:



Work on power driven equipment may only be carried out by trained or specialized personnel. Follow all applicable OSHA and local safety regulations.

The compressor unit restarts automatically after a power failure if the line pressure is lower than the pressure setting on the air pressure switch.

Lock the main disconnect switch in the "off" position in accordance with applicable lock out/tag out procedures (example: OSHA CFR 29 § 1910.147) to ensure the compressor does not restart (see chapter LEERER MERKER for main disconnect switch).

Ensure that no maintenance personnel is working on the compressor unit, that all panels are latched back on again and all maintenance doors are closed before restarting the compressor unit.

To start the compressor unit see chapter 8.1

Caution

Always tighten down any screw connection that has been loosened during maintenance work.

The following points must be observed when handling lubricating and cooling materials:



- Avoid contact with skin and eyes.
- Do not inhale vapors and oil mist.
- Do not eat or drink when handling such materials.
- Fire, open flame and smoking are strictly forbidden.

Ensure that all lubricants, consumable materials and replacement parts accumulating during operation and servicing of the compressor package are disposed of according to environmental regulations.



9.2 Regular Maintenance Work

Interval*	Maintenance tasks	see chapter	
Daily	Check the crankcase oil level.	9.3	
	Drain condensate from the air receiver.	9.4	
50 h after initial start—up			
	Change the compressor oil	9.5	
Every 500 h At least once a year	Check and clean the air filter	9.6	
	Check and clean the check valve	9.7	
	Check the safety relief valve	9.8	
Variable	Change the compressor oil	9.5	
Every 3,000 h	Check correct function of the cylinder head and valves	9.11	
Every 10,000 h	Change the motor bearings	9.9	
	Carry out a general compressor overhaul	9.11	

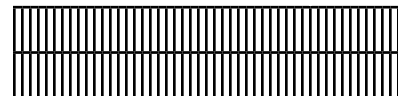

* Maintenance interval may change depending on model, installation, motor starting frequency and ambient conditions. It is recommended that a log is kept of maintenance work done. See chapter 9.13 for a sample list of maintenance tasks.

Caution

If daily maintenance is impractical because the machine is used so little, it should be carried out every 24 operating hours.

9.3 Oil Level Check and Top-Off (Compressor Block)

Check the oil level daily through the oil sight glass when the compressor unit is shut down.

Caution

If the oil level has sunk to the lower mark, top off the oil immediately according to the oil recommendations (see chapter 1.9).

Never top off to a level exceeding the maximum oil mark on the oil level sight glass.

When topping off the oil always use a strainer or pour the oil directly from the new oil can.

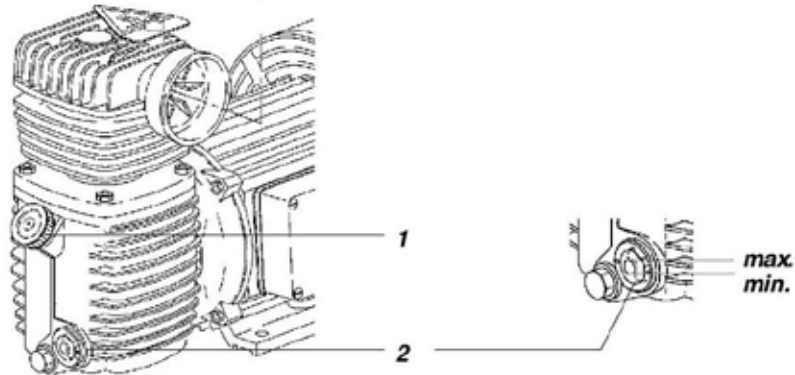

1 Oil filler with crankcase venting plug
2 Oil level sight glass

☞ Shut down the compressor (see chapter 8.1).



Lock the main disconnect in the “off” position in accordance with applicable lock out/tag out procedures (example: OSHA CFR 29 § 1910.147) to ensure the compressor does not restart. See chapter 2.4 for the main disconnect switch.

☞ Remove the crankcase venting plug (1) from the oil filler.

Caution

Let oil settle a few minutes before filling to the maximum oil level mark. The oil must flow through the crankcase first.

☞ Top off the oil to the maximum mark. See chapter 1.3 for the quantity of oil required for topping off from the minimum mark to the maximum mark

☞ Replace the crankcase venting plug in the oil filler

9.4 Air Receiver

Caution The provisions of the Pressure Vessels Act must be conformed with. The relevant regulations of the country concerned must also be observed.

Drain the condensate collecting in the air receiver daily with the condensate drain valve (1).



Drain the condensate into a suitable container and dispose of according to environmental care regulations!

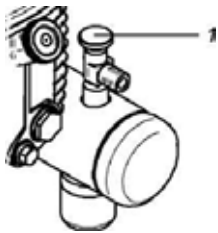

1 Condensate drain

9.5 Oil Change (Compressor Block)

Change the oil with the compressor unit at normal operating temperature.



Danger of scalding by hot oil
Danger of burns from hot components

Change the oil after approximately the first 50 service hours.

Change the oil further: see chapter 1.9.

If, under unsuitable operational conditions condensed water is observed in the oil, recognizable by the milky color in the oil level sight gauge (2), carry out an oil change immediately.



Lock the main disconnect in the “off” position in accordance with applicable lock out/tag out procedures (example: OSHA CFR 29 § 1910.147) to ensure the compressor does not restart. See chapter 2.4 for the main disconnect switch.

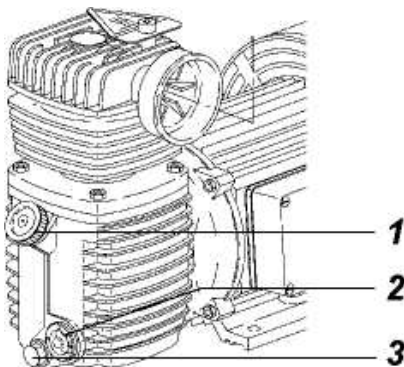

- 1 Oil Filler
- 2 Oil level sight glass
- 3 Oil drain plug



Shut down the compressor (see chapter 8.1)

Remove the crankcase venting plug (1) from the oil filler.



Prepare a container to catch the oil.



Collect the used oil and dispose in an acceptable environmental manner



Unscrew the oil drain plug (3) and drain the oil into the container.

Caution

When topping off the oil always use a strainer or pour the oil directly from the new oil can



Flush out the crankcase with a small quantity of new oil.



Screw the oil drain plug back into the crankcase



Fill up with new oil (see chapter 9.3).

9.6 Cleaning or Changing the Air Filter



The replaceable cartridge (2) is made of foam.



If an obvious layer of dust is found on the filter cartridges, they must be cleaned. The filter inserts should be cleaned at the latest after 500 service hours.



Shut down the compressor (see chapter 8.1).

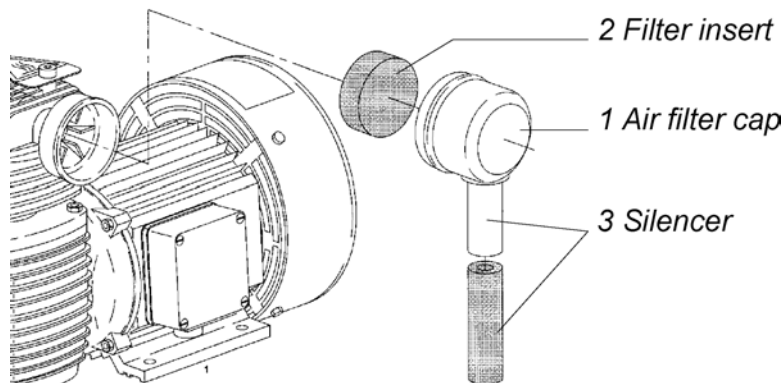

Lock the main disconnect in the "off" position in accordance with applicable lock out/tag out procedures (example: OSHA CFR 29 § 1910.147) to ensure the compressor does not restart. See chapter 2.4 for the main disconnect switch.



Remove the rubber cap of the air filter (1).



Take out the filter inserts, wash them in hot water with a grease solvent additive and then carefully rinse.



Clean out the filter housing. Clean the sealing surfaces very carefully.

Caution

If the inserts are heavily contaminated or have been cleaned several times they should be changed.



After drying the filter inserts take them again.



Fit the rubber cap of the air filter (1) again.

9.7 Cleaning or Replacing the Check Valve

The check valve is located at the inlet port of the built in air receiver. It prevents the compressed air flowing back from the air receiver into the compressor block.

Check and, if necessary, clean the check valve every 500 service hours or at least once annually

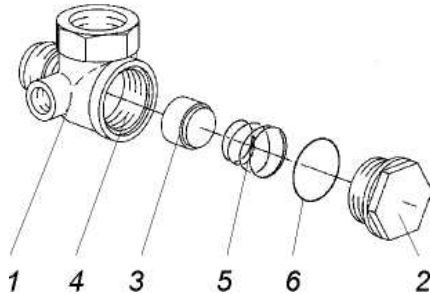

1 Check valve
2 End plug
3 Valve piston

4 Valve seat
5 Spring
6 Sealing ring

Shut down the compressor (see chapter 8.1).



Lock the main disconnect in the “off” position in accordance with applicable lock out/tag out procedures (example: OSHA CFR 29 § 1910.147) to ensure the compressor does not restart. See chapter 2.4 for the main disconnect switch.

Remove the crankcase venting plug (1) from the oil filler. Prepare a container to catch the oil.



Collect the used oil and dispose of according to environmental care regulations!

Unscrew the oil drain plug (3) and drain the oil into the container.



When topping off the oil always use a strainer or pour the oil directly from the new oil can.



Flush out the crankcase with a small quantity of new oil.

Screw the oil drain plug back into the crankcase.

Fill up with new oil (see chapter 9.3).

9.8 Testing the Safety Relief Valve

If the maximum permissible gauge working pressure in the air receiver is exceeded, the safety valve (2) opens and blows off the excess air to protect the compressor unit and the users connected to the air system.

To prevent the valve seat from sticking, activate the safety valve every 500 service hours or at least annually

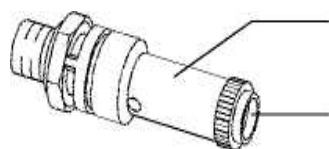

Safety valve

Knurled ring

Caution It is essential to wear ear protection when testing the pressure relief valve because of the loud noise produced by escaping air.

☞ Switch the compressor off (see chapter 8.1).

! Lock the main disconnect in the “off” position in accordance with applicable lock out/tag out procedures (example: OSHA CFR 29 § 1910.147) to ensure the compressor does not restart. See chapter 2.4 for the main disconnect switch

☞ Turn the knurled screw on the pressure relief valve anticlockwise until air escapes and then turn back again.

Caution A defective pressure relief valve must be renewed completely.

Caution Tampering with the pressure relief valve and damaging the lead seal is forbidden and will invalidate all liability.

9.9 Maintenance of the Motor Bearings

The motor bearings are sealed and lubricated for the lifetime of the bearing.

- Under normal operating conditions, with ambient temperatures around 77° F, the motor bearings should be replaced approximately every 10 000 service hours.
- The wear on the bearings increases with higher ambient temperatures. With very high ambient temperatures of around 95° F replace the bearings approximately every 6000 hours.
- Change the motor bearings every 3 years independent of service hours.

Caution The bearings must be changed by your authorized Soilmoisture distributor when the above maintenance is due.

9.10 Clean the unloading valve on the pressure switch If the machine starts with difficulty because of contamination in the unloading valve or does not vent from the pressure switch when shut down the unloading valve must be cleaned.

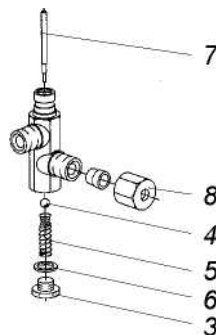
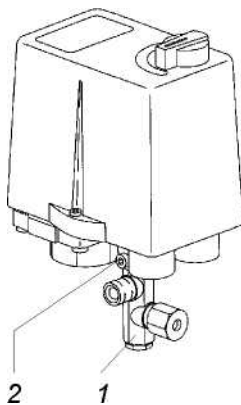

1. Unloading Valve
2. Screw
3. Screw Plug
4. Ball
5. Spring
6. Gasket
7. Valve pin
8. Fitting

- ☞ Close the user's shut-off valve between the machine and the air main.

Clean the unloading valve:

- ☞ Remove the fitting (8) from the unloading valve (1).
- ☞ Remove the securing screw (2) and lift off the unloading valve (1).

Caution Open the valve carefully.

- ☞ Remove the plug (3) and take out the individual parts.
- ☞ Extract the valve pin (7) and clean it and the other parts.
- ☞ Reassemble and replace the valve and tighten the securing screw (2)

Start the machine and carry out a test run

- ☞ Open the user's shut-off valve between the machine and the air main.
- ☞ Switch the machine on.
- ☞ Carry out a visual check for leaks.

9.11 Inspect the cylinder head and valves and renew if required

Check the function of the cylinder head and valves after 3 000 operating hours. In addition, inspect the valve plates for coking and clean if necessary.

If the cylinder head or valves show sign of malfunction they should be repaired or renewed by an authorized Soilmoisture facility.

We recommend a general overhaul of the machine should be carried out at a Soilmoisture facility after 10, 000 operating hours.

9.12 Checking Compressor Unit Performance

- ☞ The effective compressor unit performance can be determined by measuring the charging time of the air receiver. Shut down the compressor unit (see chapter 8.1).

Lock the main disconnect in the "off" position in accordance with applicable lock out/ tag out procedures (example: OSHA CFR 29 §

- ☞ Isolate the compressor from the air main (close the user's shut—off valve).
- ☞ Vent the air receiver with the condensate drain cock and then close the cock again (see chapter 9.4).
- ☞ Close the shut-off valve on the air receiver.
- ☞ Start the compressor unit (see chapter 8.1) and simultaneously measure and compare the charging time taken to achieve the gauge pressure stated in the technical specification (see chapter 1.10).

10 Spare Parts and After Sales Service

10.1 Service Parts and Maintenance Parts

Name	Qty.	Part number
Air filter insert	1	0505V-0000-01
Check valve	1	0505V-0000-02

		Model 505 20 Bar Compressor Series	
Part No.	0505V2206	Test Press.	35 Bars (441 psi)
Serial No.	505-1001 - R	Yr. of Mfg.	200_
Receiver Vol.	4 Liters (61 cu. in)	Press Relief Set	21.37 Bars (310 psi)
Shell Thk.	34.04 mm (.134 in)	Avg Delv. at 6 Bars	80L/min (2.83 cfm)
End Cap Thk.	30.23 mm (.119 in)	Country of Mfg	Germany
Max Pressure	20 Bar (294 psi)	SOILMOISTURE EQUIPMENT CORP., 801 S. Kellogg Ave. Goleta, CA., USA Ph. 805-964-3525 Fax. 805-683-2189 http://www.soilmoisture.com	

10.2 Ordering Spare Parts

When ordering spare parts always state (see nameplate):

- Compressor model
- Serial Number
- Year of manufacture



Important for all orders and inquiries:

Enter the data from the nameplate of the compressor unit in the nameplate shown above.



Always order original spare parts from the compressor manufacturer to avoid lower quality spare parts in your compressor unit.

We want to point out that maintenance parts, spare parts and accessories not supplied by us are also not tested and authorized by us. The use of such products could change design characteristics of the compressor unit negatively and might therefore affect the safety of the unit.

It should be noted that substitution of original parts or assemblies will void the warranty coverage in most circumstances and in worst case expose the user to hazards and liabilities not covered by the manufacturer or supplier of this compressor.



11.0 Appendix Electrical Diagram Compressor Wiring

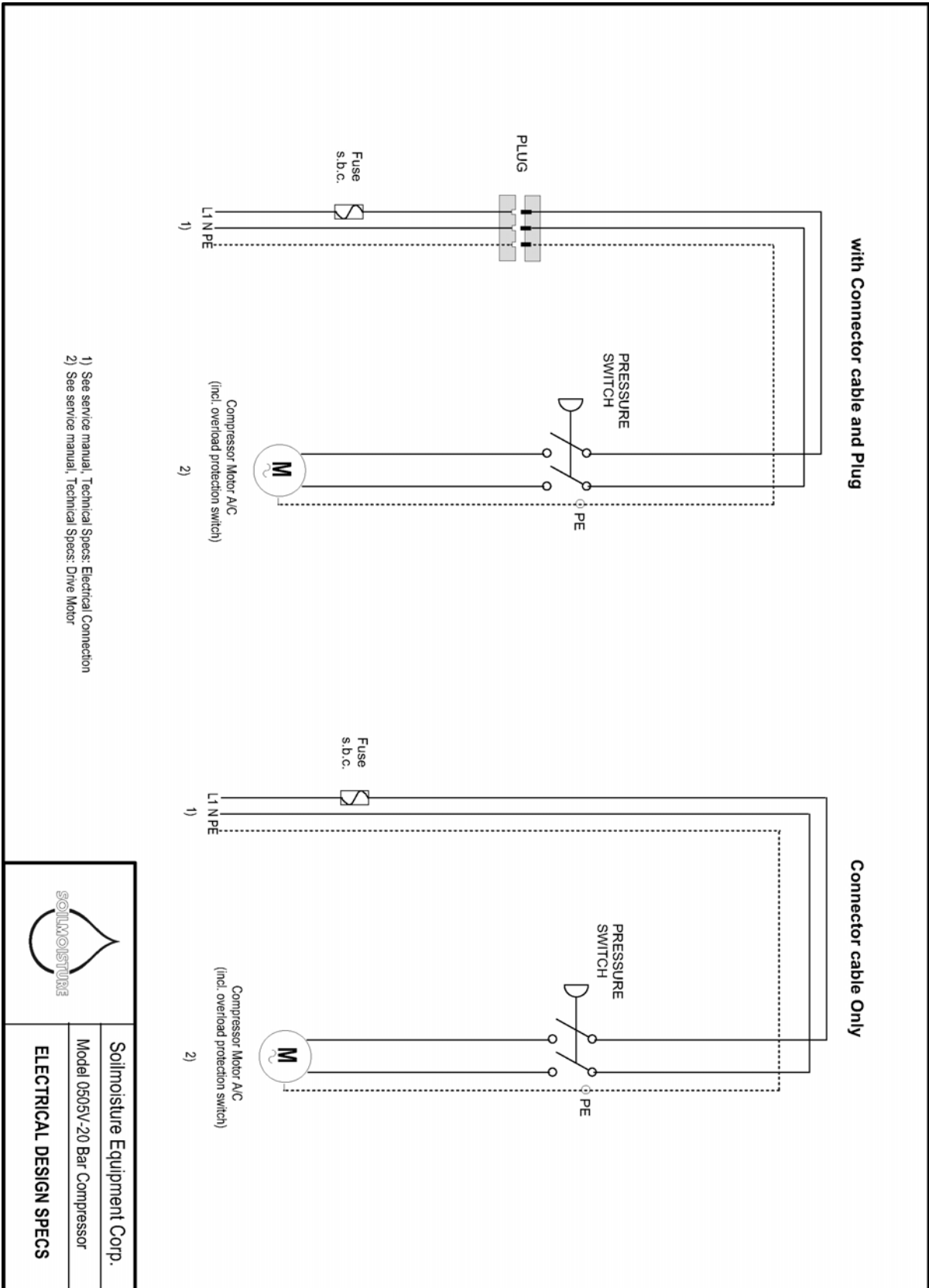

**With dealers throughout the world,
you have convenience of purchase and assurance
of after-sales service.**

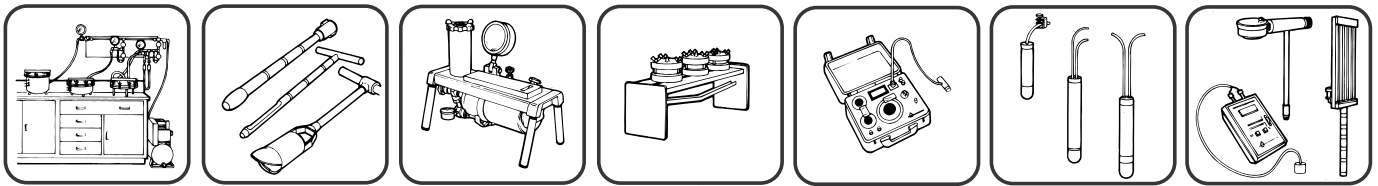

© COPYRIGHT 2009 ALL RIGHTS RESERVED 0898-0505V